

IQ SOFT

Smart softener



- Programming the device can be done via your smartphone.
- Monitor your water softener and water usage from a distance.
- Receive an alert when your salt needs refilling.





IQ SOFT

Smart softener
9L / 12L / 18L / 25L



FEATURES

- ◆ 4 buttons with straight forward combinations for enter settings and start a regeneration. Info button shows instructions directly on the display
- ◆ Larger graphic display with RGB colors
- ◆ Software includes 7 languages
- ◆ Easy programming, with all settings, except hardness and time/date, factory-set to optimum values
- ◆ Ultra-compact footprint allows installation even in the narrowest locations
- ◆ High efficiency regeneration with proportional brining and smart reserve algorithm
- ◆ Integrated handles make for simple and easy installation
- ◆ Salt alarm
- ◆ Integrated bypass
- ◆ Holiday mode
- ◆ Customize your softener loading password, parameters and your company name with USB-C pen drive
- ◆ Wi-Fi Connectivity

Our IQ Soft water softener is the most advanced solution for tackling hard water.

A compact footprint and state-of-the-art design combine to make IQ Soft softeners a major breakthrough in the water treatment industry. No other softener comes close to matching its high-end specification, ease of installation or soft water benefits.

Monitor your water usage via your smartphone.

While our IQ Soft softener is giving you perfectly softened water, its Wi-Fi technology can provide peace of mind by monitoring your water usage and managing your softener via smartphone or tablet. If you are planning a holiday, the *ConnectMySoftener* App features a 'holiday mode' to avoid unnecessary consumption of water while you are away. Our IQ Soft water softener is the most advanced solution for tackling hard water.

BENEFITS

- ➔ Intuitive User Interface allows users and installers to get straight away familiar with it and any setting change is extremely easy and fast to make
- ➔ Optimum readability and customizability of the displayed values. RGB backlight works like a status led to provide immediate and straight forward feedback on the actual status of the appliance
- ➔ Perfectly adapts for installation in most of the European countries.
- ➔ Quick start up procedure and peace of mind knowing the product will perform at its best.
- ➔ Suitable for installation where space saving is important and under the sink installations
- ➔ Exceptionally low rinse water usage per regeneration leads to minimal salt consumption, with up to 20% salt-saving compared to previous model
- ➔ Ergonomic and suitable for installation even in the smallest of spaces
- ➔ Never runs out of salt without noticing, the remaining salt % is always shown in the display. If the system is connected to the Wi-Fi you will get a notification on *ConnectMySoftener* when it is time to refill the brine tank
- ➔ Simplified installation and system maintenance
- ➔ Holiday mode avoids unnecessary regeneration, resulting in reduced water and salt consumption during periods of absence, while maintaining the resin bed in optimal condition for service
- ➔ Allows to quickly upload your settings and your customizations such your company name service assistance phone number directly in the display
- ➔ Professionals can remotely monitor the softener from the *ConnectMySoftener* portal & Homeowners can get notification on the softener status and water & Salt usage on the *ConnectMySoftener* app



INTRODUCING THE *CONNECTMYSOFTENER* PORTAL FOR IQ SOFT CUSTOMERS!

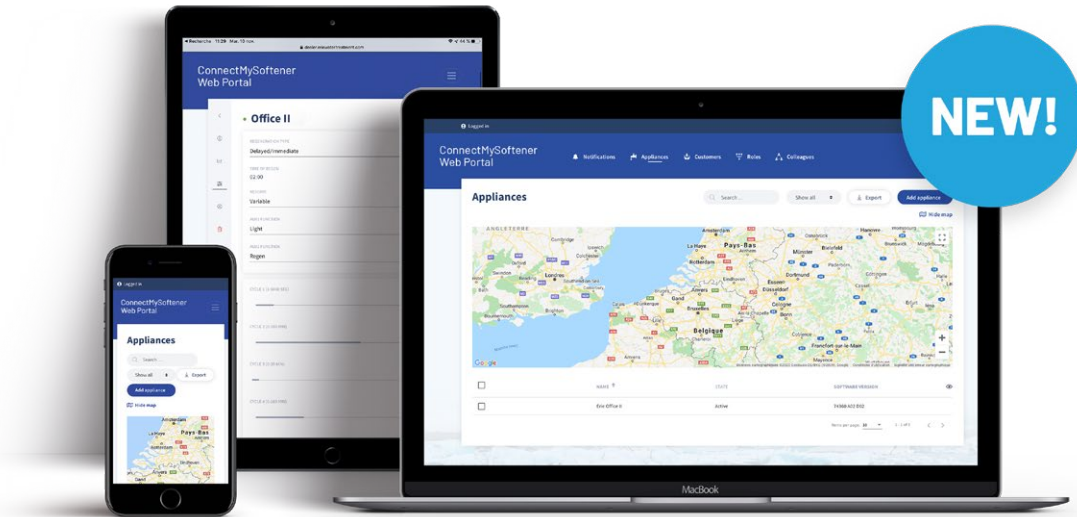

We would like to remind you the implementation of our new **ConnectMySoftener portal** recently launched.
<https://connectmysoftener.pentair.eu/login>

Designed to get the most out of the product and to give our dealers optimal support, the *ConnectMySoftener* portal allows dealers to monitor and service their customer installations online, allowing remote management of the equipment through any laptop, tablet or smartphone with internet connection.

The entire management is in the dealer's 'online' hands. Please note that this new web portal is specifically intended for IQ Soft customers.

If you have questions about the portal, please do not hesitate to contact us on ConnectMySoftenerProSupportEU@pentair.com.

CUSTOMER BENEFITS



ALWAYS VIGILANT AND INFORMED



UNIQUE 2-WAY COMMUNICATION



EASY TO USE



SAVE TIME, SAVE MONEY



EXTENSIVE SERVICING POTENTIAL



GEOLOCALIZATION OF ALL EQUIPMENT



IMPROVED CUSTOMER AND DATA MANAGEMENT

TECHNICAL SPECIFICATIONS

CHARACTERISTICS	IQ Soft CS micro 0913 9L	IQ Soft CS mini 0916 12L	IQ Soft CS midi 0922 18L	IQ Soft CS maxi 0930 25L
Part number	S4035296	S4035297	S4035298	S4035299
Resin volume (L)	9 L	12 L	18 L	25 L
Number of people	1-2	3-6	5-8	7-8
Nominal flow rate (m ³ /h) (residual hardness 0 ^o f)	0,5 m ³ /h	0,7 m ³ /h	1,1 m ³ /h	1,5 m ³ /h
Nominal flow rate (m ³ /h) (residual hardness 5-10 ^o f)	0,6 m ³ /h	0,9 m ³ /h	1,3 m ³ /h	1,8 m ³ /h
Peak flow rate (m ³ /h) (residual hardness 5-10 ^o f)	0,9 m ³ /h	1,2 m ³ /h	1,8 m ³ /h	2,5 m ³ /h
Salt dosage g/resin (standard settings)	80 g/l	80 g/l	80 g/l	80 g/l
Salt consumption per regeneration (kg)	0,7 Kg	1,0 Kg	1,4 Kg	2,0 Kg
Water consumption per regeneration (L)	38 L	51 L	74 L	98 L
Softener capacity °f x m ³	43,6 °f • m ³	58,1 °f • m ³	87,1 °f • m ³	121,0 °f • m ³
Capacity in m ³ for 30 ^o f inlet water hardness and 10 ^o f residual hardness setting	2,2 m ³	2,9 m ³	4,4 m ³	6,1 m ³
In / out connections	3/4" BSPT	3/4" BSPT	3/4" BSPT	3/4" BSPT
Drain connection	1/2" hose	1/2" hose	1/2" hose	1/2" hose
Tank size	9x13	9x16	9x22	9x32
Operating pressure min/max (bar)	1,4 / 8,3			
Operating temperature min/max (°C)	2 / 48			
Electrical connection (V/Hz)	230AC /12 VAC - 50/60 Hz			
Max power consumption (VA)	6,5			
Accessories included	Plastic bypass - Universal hardness test kit, single bottle, °f/°d - Voltage transformer 230-12V AC - 3/4 BSP male in/out connection kit - 3 mtr reinforced drain hose with 2 clamps - Air gap with double drain connection			
Regeneration type	High efficiency regeneration with smart reserve & Proportional brining			
System interface	Multilanguage RGB graphic display			
Salt compartment capacity in kg	13,0 kg	17,0 kg	23,0 kg	35,0 kg
Product width	280 mm	280 mm	280 mm	280 mm
Product height	497 mm	575 mm	728 mm	982 mm
Product depth	438 mm	438 mm	438 mm	438 mm
Product depth with bypass assembled	540 mm	540 mm	540 mm	540 mm
Product weight	15,5 kg	20,0 kg	26,5 kg	36,0 kg
Packaging dimension (WxLxH) mm	400 x 480 x 680	400 x 480 x 680	470 x 320 x 760	470 x 302 x 1020
Quantity per pallet	7	7	7	7

Note: All calculations are based on a salt dosage setting standard of the PCB. The softener installation takes into account a pre-filter made of a 10" filter housing (Pentair ref. 150543) and a 10" 100micron Wound cartridge (Pentair ref. WWP100P10).

* Indicatives data. Maximum flow rate to produce in order to respect the required service velocity for an optimal ion exchange upon resin manufacturers recommendation, regardless of the inlet pressure.

** Values may vary upon local condition and programming. All consumptions are given for an inlet pressure of 3 bar.



ACCESSORIES

- ◆ Plastic bypass
- ◆ Universal hardness test kit, single bottle, °f/°d
- ◆ Voltage transformer 230-12V
- ◆ ¾ BSP male in/out connection kit
- ◆ 3 mtr reinforced drain hose with 4 clamps
- ◆ Air gap with double drain connection

OUTLINE DRAWINGS

IQ Soft Water softener 25L

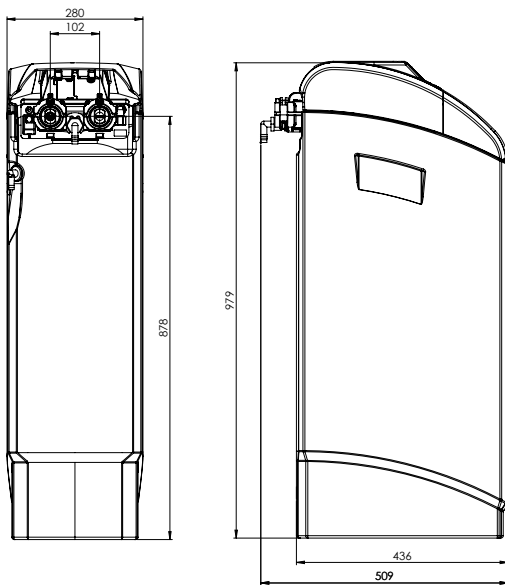

IQ Soft Water softener 18L

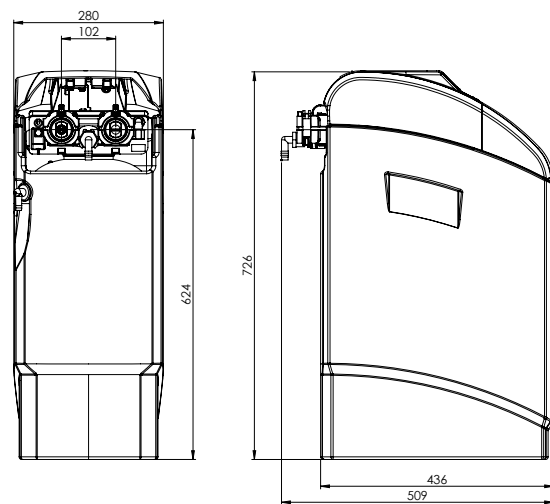

IQ Soft Water softener 12L

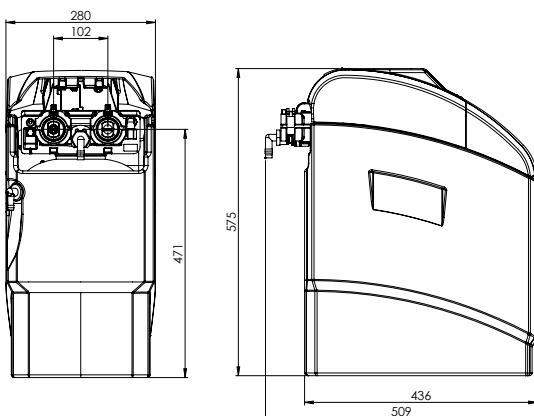

IQ Soft Water softener 9L

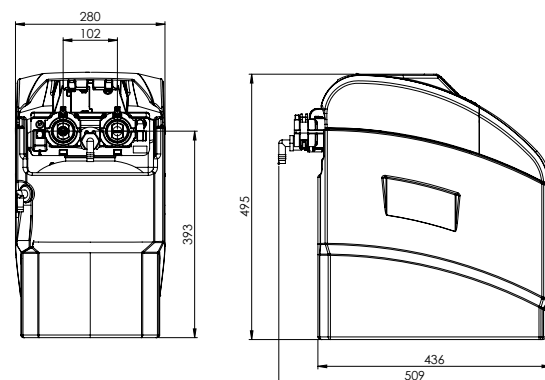

www.pentair.eu

All indicated Pentair trademarks and logos are property of Pentair. Third party registered and unregistered trademarks and logos are the property of their respective owners.

MKT-TS-184-EN-C © 2024 Pentair. All rights reserved.