

# SLIMLINE

Smart softener





# SLIMLINE

Water softener  
12L / 15L / 30L



## FEATURES

- ◆ 4 buttons with straight forward combinations for enter settings and start a regeneration. Info button shows instructions directly on the display
- ◆ Larger graphic display with RGB colors
- ◆ Software includes 7 languages
- ◆ Easy programming, with all settings, except hardness and time/date, factory-set to optimum values
- ◆ Compact size
- ◆ High efficiency regeneration with proportional brining and smart reserve algorithm
- ◆ Integrated handles make for simple and easy installation
- ◆ Salt alarm
- ◆ Integrated bypass
- ◆ Holiday mode
- ◆ Customize your softener loading password, parameters, and your company name with USB-C pen drive
- ◆ Wi-Fi Connectivity\*

\* Only on the SKUs which have this feature

## Our SlimLine water treatment systems protect you and your home.

The SlimLine water softeners are equipped with the latest technology. This way they deliver the best performance and guarantee a carefree water supply.

Thanks to its wifi connection available as an option, users can control the SlimLine via the [Pentair ConnectMySoftener app](#), whilst pros can have access to the [ConnectMySoftener portal](#).

SlimLine is available with or without wifi connectivity. If you want to know more about which version feature the connectivity, please refer to our catalogue or pricelist

DOWNLOAD THE APP NOW!



## BENEFITS

- ➔ Intuitive User Interface allows users and installers to get straight away familiar with it and any setting change is extremely easy and fast to make
- ➔ Optimum readability and customizability of the displayed values. RGB backlight works like a status led to provide immediate and straight forward feedback on the actual status of the appliance
- ➔ Perfectly adapts for installation in most of the European countries.
- ➔ Quick start up procedure and peace of mind knowing the product will perform at its best.
- ➔ Suitable for installation where space saving is important
- ➔ Exceptionally low rinse water usage per regeneration leads to minimal salt consumption, with up to 20% salt-saving compared to previous model
- ➔ Ergonomic and suitable for installation even in the smallest of spaces
- ➔ Never runs out of salt without noticing, the remaining salt % is always shown in the display. If the system is connected to the Wi-Fi you will get a notification on ConnectMySoftener when is time to refill the brine tank
- ➔ Simplified installation and system maintenance
- ➔ Holiday mode avoids unnecessary regeneration, resulting in reduced water and salt consumption during periods of absence, while maintaining the resin bed in optimal condition for service
- ➔ Allows to quickly upload your settings and your customizations such your company name service assistance phone number directly in the display
- ➔ Professionals can remotely monitor the softener from the ConnectMySoftener portal & Homeowners can get notification on the softener status and water & Salt usage on the ConnectMySoftener app

**TECHNICAL SPECIFICATIONS**

CHARACTERISTICS	SlimLine CS mini 10x15 12L	SlimLine CS midi 10x19 15L	SlimLine CS maxi 1030 28L
Part number	S4035289	S4035290	S4035387
Resin volume (L)	<b>12 L</b>	<b>15 L</b>	<b>28 L</b>
Number of people	1-2	5-6	7-8
Nominal flow rate (m <sup>3</sup> /h) (residual hardness 0 <sup>o</sup> f)	0,7 m <sup>3</sup> /h	0,9 m <sup>3</sup> /h	1,7 m <sup>3</sup> /h
Nominal flow rate (m <sup>3</sup> /h) (residual hardness 5-10 <sup>o</sup> f)	0,9 m <sup>3</sup> /h	1,1 m <sup>3</sup> /h	2,0 m <sup>3</sup> /h
Peak flow rate (m <sup>3</sup> /h) (residual hardness 5-10 <sup>o</sup> f)	1,2 m <sup>3</sup> /h	1,5 m <sup>3</sup> /h	2,8 m <sup>3</sup> /h
Salt dosage g/resin (standard settings)	80 g/l	80 g/l	80 g/l
Salt consumption per regeneration (kg)	1,0 Kg	1,2 Kg	2,2 Kg
Water consumption per regeneration (L)	51 L	64 L	110 L
Softener capacity °f x m <sup>3</sup>	58,1 °f • m <sup>3</sup>	72,6 °f • m <sup>3</sup>	135,5 °f • m <sup>3</sup>
Capacity in m <sup>3</sup> for 30 <sup>o</sup> f inlet water hardness and 10 <sup>o</sup> f residual hardness setting	2,9 m <sup>3</sup>	3,6 m <sup>3</sup>	6,8 m <sup>3</sup>
In / out connections	3/4" BSPT	3/4" BSPT	3/4" BSPT
Drain connection	1/2" hose	1/2" hose	1/2" hose
Tank size	10x15	10x19	10x30
Operating pressure min/max (bar/MPa)	1,4 / 8,3 - 0.14 / 0,83		
Operating temperature min/max (°C)	3 / 40		
Electrical connection (V/Hz)	230 VAC/12 VAC - 50/60 Hz		
Max power consumption (W)	6 W		
Accessories included	Plastic bypass - Voltage transformer 230-12V AC - 3/4 BSP male in/out connection kit - 3 mtr reinforced drain hose with 2 clamps - Air gap with double drain connection		
Regeneration type	High efficiency regeneration with smart reserve & Proportional brining		
System interface	Multilanguage RGB graphic display		
Salt compartment capacity in kg	25,0 kg	37,0 kg	65,0 kg
Product width	352 mm	352 mm	391 mm
Product height	546 mm	680 mm	965 mm
Product depth	442 mm	442 mm	467 mm
Product depth with bypass assembled	525 mm	525 mm	550 mm
Product weight	19,5 kg	25,0 kg	41,0 kg
Packaging dimension (WxLxH) mm	390x480x580	390x480x710	390x480x1010
Quantity per pallet	12	12	6

**Note:** All calculations are based on a salt dosage setting standard of the PCB. The softener installation takes into account a pre-filter made of a 10" filter housing (Pentair ref. 150543) and a 10" 100micron Wound cartridge (Pentair ref. WWP100P10).

\* Indicatives data. Maximum flow rate to produce in order to respect the required service velocity for an optimal ion exchange upon resin manufacturers recommendation, regardless of the inlet pressure.

\*\* Values may vary upon local condition and programming. All consumptions are given for an inlet pressure of 3 bar.



**OUTLINE DRAWINGS**

**SlimLine CS mini 1015 12L**

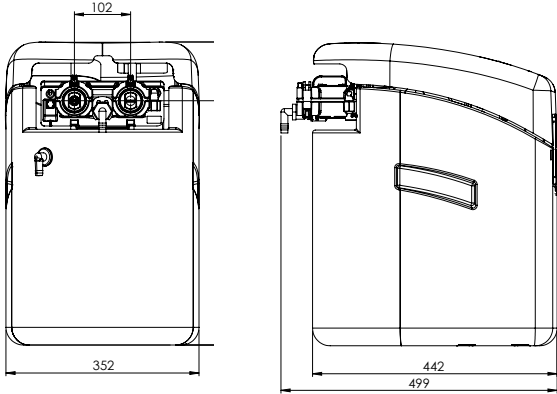

**SlimLine CS maxi 1030 28L**

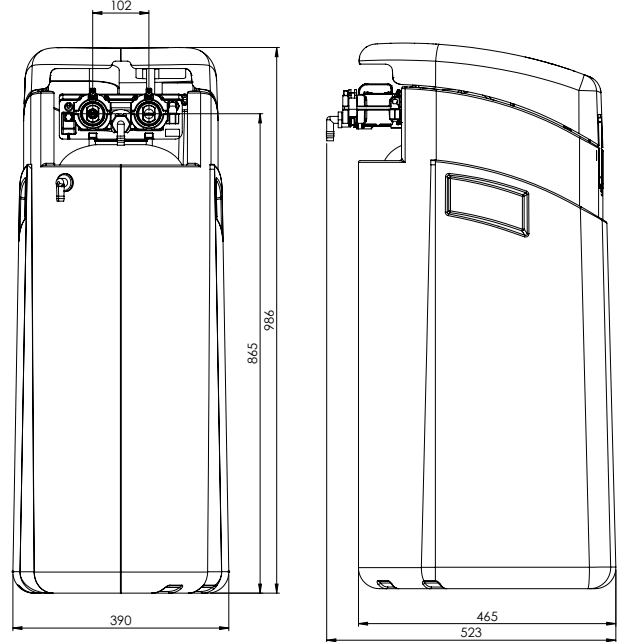

**SlimLine CS midi 1018 15L**

