

# BEER ACE II

Universal beer pump





# BEER ACE II

## Universal beer pump

84-535-16



### Does not affect carbonation.

The Beer ACE II gas or air operated pump is **designed to dispense any type of beer** through long or short, vertical or horizontal pipe runs even with small bore tubing, typically 1/4" (6mm) internal diameter.

**Beer and drive gas are totally separated.** Changing the pumping pressure does not affect the internal carbonation pressure of the beer. In consequence beer can be dispensed in the condition intended by the brewer.

The pump has been developed by SHURflo's thoroughly proven gas pump family, **known worldwide for reliability over a long working life.** In this latest design enlarged pumping chambers and a longer stroking piston enable a given volume of beer to be dispensed with fewer piston strokes and reduced pump wear.

These features and a short straight liquid flow path produce an even smoother flow, while pump life is increased by as much as 30%.

External features of Beer Ace II include a smoothly contoured body in crack resistant polypropylene. **Quick disconnect slide locks for gas-in, liquid-in and liquid-out ports allow easy installation.**

### FEATURES & BENEFITS

- ▶ Separates CO<sub>2</sub> quality control, pressure and flow rate needs into **independent functions**
- ▶ **Dispense speed can be altered** without over carbonating beer
- ▶ Handles long and difficult pipe runs, **even with small bore tubing**
- ▶ Smooth flow and **up to 30% longer pump life.**
- ▶ Enlarged pumping chambers and long piston stroke in new design gives **desired flow rate with fewer cycles and reduced wear**
- ▶ Quick-disconnect ports for **fast installation**

### BEER ACE II PUMP

New smooth body is easier to keep clean and can handle higher operating pressure

Heavy duty actuator mechanism increases life

Hydraulic advantage on inside of piston and air on outside reduces pressure drop

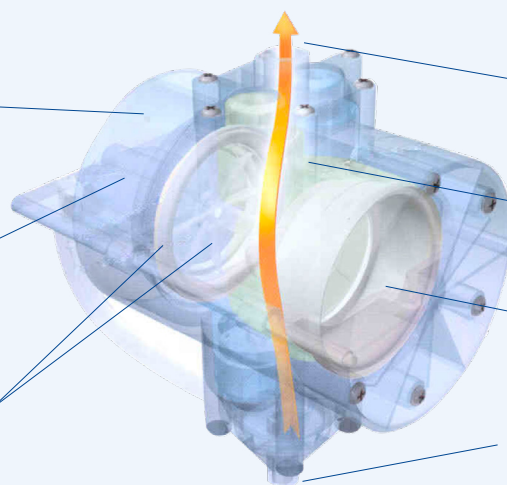

Straight through flow path

30% Larger pumping volume

One piece piston diaphragm

Quick disconnect fittings reduces labor and parts when replacing pumps

# BEER ACE II

## Universal beer pump

84-535-16

### SPECIFICATIONS

- ▶ **Design**  
Two chambers double diaphragm
- ▶ **Power source**  
CO<sub>2</sub> gas, nitrogen or clean compressed air
- ▶ **Materials of construction**  
Polypropylene, EPDM, TPU, stainless steel
- ▶ **Temperature limits**  
-1.1 to 49°C (30 to 120°F) - No freezing
- ▶ **Weight**  
0.5 Kg (1.2 Lbs)
- ▶ **Size**  
201 mm H x 145 mm W x 97 mm D (7.9" x 5.7" x 3.8")
- ▶ **Fittings**  
A wide variety of both gas and liquid fittings are available to fit your needs; please refer to our dedicated tech sheet reporting all available options
- ▶ **Displacement**  
100 cc (3.4 oz) per cycle
- ▶ **Automatic sold out**  
27-37 kPa (6-12" Hg) activation (wet)
- ▶ **Maximum operating pressure**  
5.9 Bar (85 psi)
- ▶ **Minimum operating pressure**  
1.4 Bar (20 psi)
- ▶ **Regulatory**  
EU Food

### DIMENSIONS:

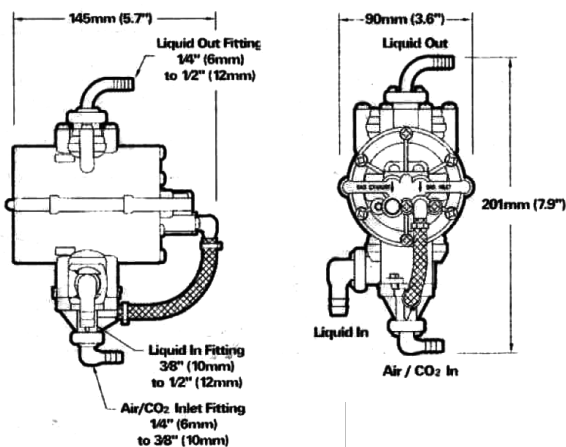

[www.pentair.eu](http://www.pentair.eu)

Pentair trademarks and logos are owned by Pentair plc or its affiliates. For a detailed list of where Pentair trademarks are registered, please visit [www.pentair.com/en/registrations.html](http://www.pentair.com/en/registrations.html). Third party registered and unregistered trademarks and logos are the property of their respective owners. Because we are continuously improving our products and services, Pentair reserves the right to change specifications without prior notice.

MKT-TS-XXX-EN-A ©2025 Pentair Filtration Solutions, LLC. All Rights Reserved.

### PRESSURE DROP @ 1 GPM

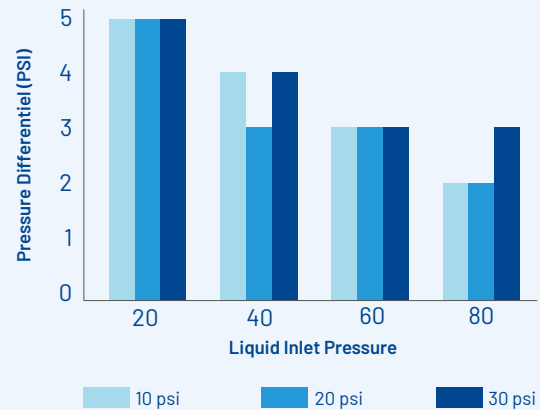

### MAXIMUM FLOW RATE

