

HDA BEVERAGE GAS PUMP

Heavy Duty Advantage

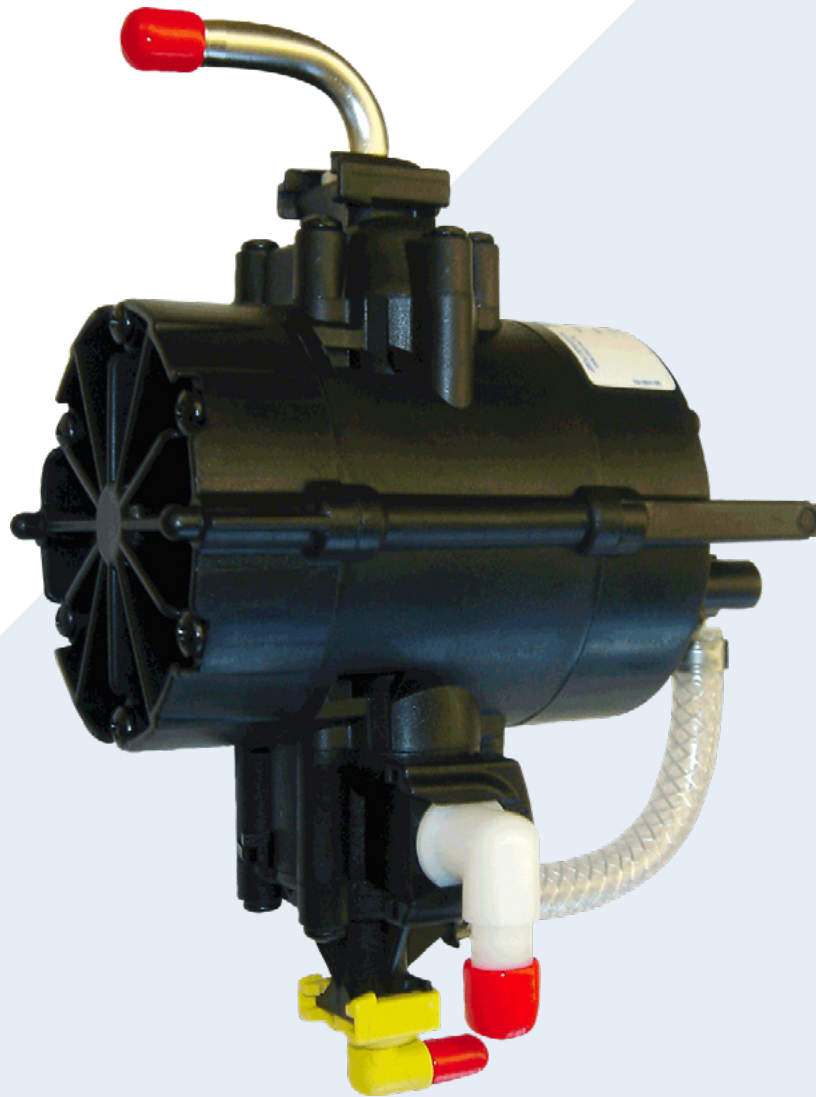



HDA BEVERAGE GAS PUMP

Heavy Duty Advantage

166-296-28

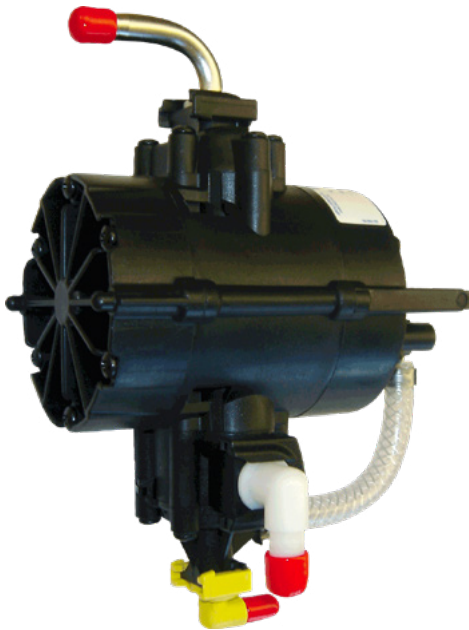

Lowest pressure drop in the industry.

The purpose of any pump is to deliver the syrup in a way that maximizes the ratio ability of the dispensing valve. A pressure drop occurs every time the dispensing valve opens and closes. **The lower the pressure drop, the more consistent the pressure, the more consistent the drink.**

The HDA Pump has a straight simplified syrup path, larger pumping chambers, and a configuration between the syrup and air that results in a hydraulic advantage. **The result is precise steady delivery of syrup to the dispenser head, insuring consistent beverage quality.**

Higher volume per stroke reduces the number of cycles and extends pump life by 30%. The pump body is made of crack-resistant polypropylene. You can depend on consistent syrup delivery and long reliable pump life with the HDA Pump.

The path to consistency is simple with the Heavy Duty Advantage Pump.

FEATURES & BENEFITS

- ▶ **Straight, short, simplified** syrup path for consistent, efficient delivery
- ▶ High volume per stroke, **produces less wear and 30% longer pump life**
- ▶ **Operating pressure to 85 psi** can handle the most difficult installations, suitable for all pump needs

HEAVY DUTY ADVANTAGE PUMP

New smooth body is easier to keep clean and can handle higher operating pressure

Heavy duty actuator mechanism increases life

Hydraulic advantage-syrup on inside of piston and air on outside reduces pressure drop

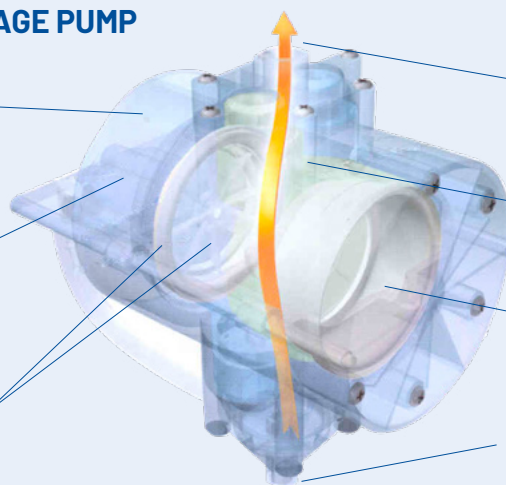

Straight through flow path

30% Larger pumping volume

One piece piston diaphragm

Quick disconnect fittings reduces labor and parts when replacing pumps

HDA BEVERAGE GAS PUMP

Heavy Duty Advantage

166-296-28

SPECIFICATIONS

- ▶ **Design**
Two chambers double diaphragm
- ▶ **Power source**
CO₂ gas, nitrogen or clean compressed air
- ▶ **Materials of construction**
Polypropylene, EPDM, TPU, stainless steel
- ▶ **Temperature limits**
1.1 to 49°C (34 to 120°F)
- ▶ **Weight**
0.5 Kg (1.2 Lbs)
- ▶ **Size**
201 mm H x 145 mm W x 97 mm D (7.9" x 5.7" x 3.8")
- ▶ **Fittings**
Gas inlet: ¼" (6 mm) barbed elbow yellow plastic with check valve
Gas outlet: ¼" (6 mm) barbed elbow white plastic
Liquid inlet: ⅜" (10 mm) barbed elbow white plastic
Liquid outlet: ¼" (6 mm) barbed elbow stainless steel
- ▶ **Displacement**
100 cc (3.4 oz) per cycle
- ▶ **Suction lift (wet)**
847 mm bar (25 in. Hg)(min)
- ▶ **Maximum operating pressure**
85 psi (5.9 bar)
- ▶ **Minimum operating pressure**
20 psi (1.4 bar)
- ▶ **Regulatory**
EU Food

DIMENSIONS

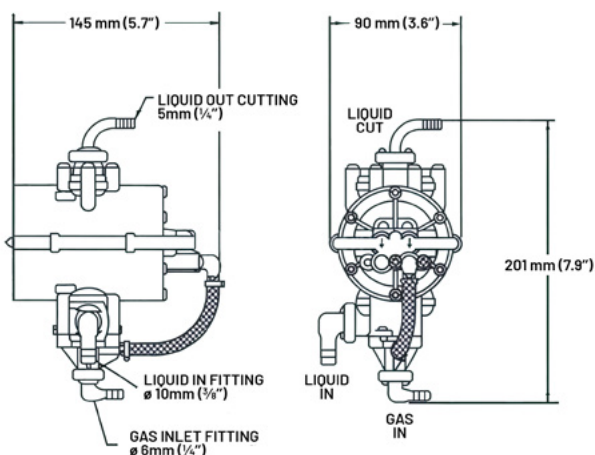

www.pentair.eu

Pentair trademarks and logos are owned by Pentair plc or its affiliates. For a detailed list of where Pentair trademarks are registered, please visit www.pentair.com/en/registrations.html. Third party registered and unregistered trademarks and logos are the property of their respective owners. Because we are continuously improving our products and services, Pentair reserves the right to change specifications without prior notice.

MKT-TS-200-EN-A ©2025 Pentair Filtration Solutions, LLC. All Rights Reserved.

LOWEST PRESSURE DROP IN THE INDUSTRY

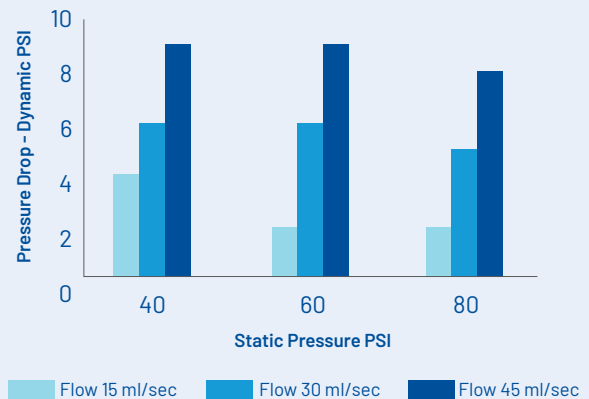

Note: for reference only
Media: Cola Syrup

PRESSURE VS. FLOW CHART

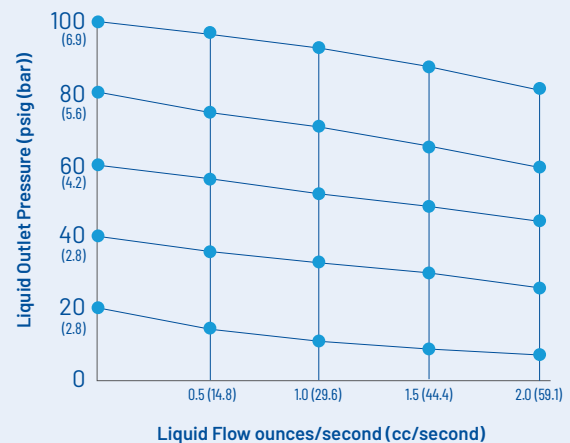

Note: Flow curve varies with product viscosity
Media: Cola Syrup